

Avibulb XT[®] & Avinox XT[®]

Avibulb[®] XT (steel) and Avinox[®] XT (stainless steel) fasteners are high performance structural breakstem fasteners with excellent bulbing tail formation, ideal for thin sheet materials. The new fasteners feature a wide grip range, especially suited for applications with varying sheet thicknesses



Avibulb XT[®]



Avinox XT[®]

Key Features and Benefits for Avibulb XT & Avinox XT Fasteners

- High shear and tensile strength and high residual clamp load providing strong, vibration resistant joints
- Multi-grip capability accommodates wide variations in material thickness
- Spreads the tail bearing load/clamp load on the rear sheet making it ideal for use in thin sheet materials
- Suitable also in softer materials
- Retained stem avoids damage, electrical problems or rattling caused by loose stems
- Underhead recess accommodates burrs around holes and spreads the load evenly on the top sheet
- Stainless steel Avinox[®] XT for high corrosion resistance and applications requiring elevated temperatures

Specifications

Sizes:

6.4 mm (1/4")

Materials:

Steel, Stainless Steel

Head Style:

Dome

Typical Placing Sequence

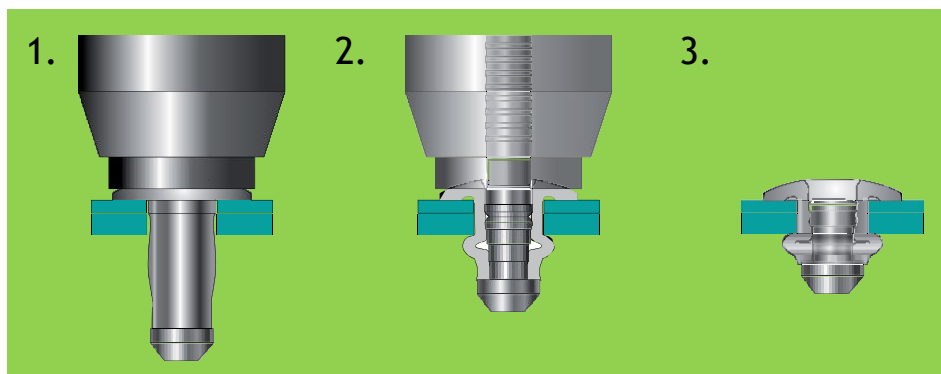

Assembly Applications for Avibulb XT & Avinox XT Fasteners

- Automotive
- Truck and trailer
- Cabinets and enclosures
- Heating and ventilation
- Telecommunications
- Domestic appliances
- Renewable energy
- Industrial equipment

