

Avibulb[®] & Avinox[®] Fasteners

High strength steel (Avibulb[®]) and stainless steel (Avinox[®]) breakstem fasteners with excellent bulbing tail formation. Ideal for thin sheet materials.



Key Features and Benefits of Avibulb & Avinox fasteners

- High shear and tensile strength providing strong, vibration resistant joints
- Stainless steel Avinox[®] for high corrosion resistance and applications requiring elevated temperatures
- Provides a large blind side bearing area against the rear sheet
- Spreads the tail bearing load/clamp load on the rear sheet making it ideal for use in thin sheet materials
- Good hole fill compensates for irregular, oversized, slotted or misaligned holes
- Retained stem avoids damage, electrical problems or rattling caused by loose stems

Specifications

Sizes:

3.2 mm – 4.8 mm

(1/8" – 3/16"),

Avibulb[®] up to 6.0 mm

Materials:

Steel, Stainless Steel,

A4 Stainless Steel

Head Style:

Dome

Typical Placing Sequence

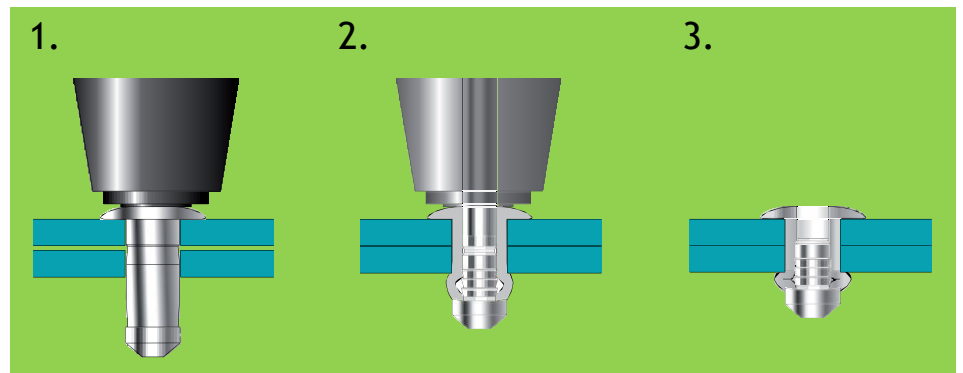

Assembly Applications for Avibulb & Avinox Fasteners

- Automotive
- Cabinets and enclosures
- Heating and ventilation
- Telecommunications
- General light industrial
- Marine engineering
- Medical equipment

