

Bulbex[®] Fasteners

Aluminium alloy breakstem fasteners with a split tail formation providing a very large blind side bearing area against the rear sheet. Ideal for use with plastic and low strength material.



Key Features and Benefits of Bulbex Fasteners

- Split tail formation provides a very large blind side bearing area against the rear sheet
- Spreads the tail bearing load/clamp load on the rear sheet providing high resistance to pull-out loads
- Multi-grip capability accommodates wide variations in material thickness
- Retained stem avoids damage, electrical problems or rattling caused by loose stems

Specifications

Sizes:

3.2 mm, 4.0 mm and
4.8 mm
(1/8", 5/32" and 3/16")

Material:

Aluminium Head

Styles:

Dome, Large Flange

Typical Placing Sequence

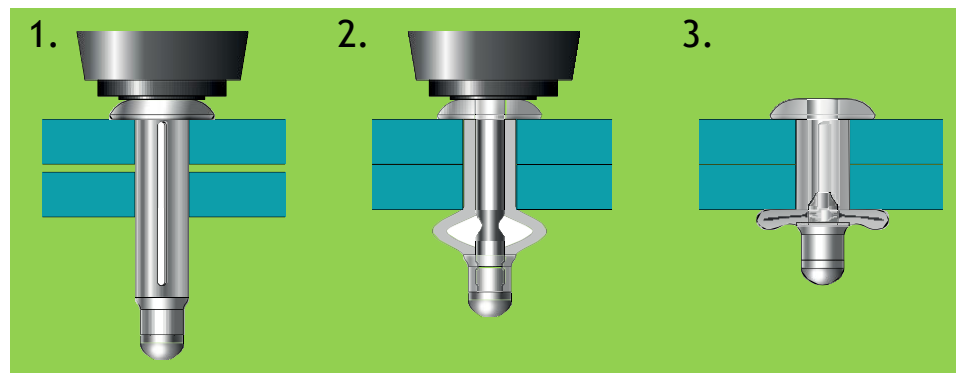

Assembly Applications for Bulbex Fasteners

- Automotive
- Caravans/RV
- HVAC
- Domestic appliances
- Plastic components

