

Hemlok[®] Fasteners

Structural breakstem fasteners with exceptional shear and tensile strength and a large blind side bearing area against the rear sheet.



Key Features and Benefits for Hemlok Fasteners

- All steel version provides exceptional shear and tensile strength
- Large blind side bearing area spreads the tail bearing load/clamp load on the rear sheet reducing creep e.g. in plastic material
- Interference lock formed by a splined stem provides strong, vibration resistant joints
- No damage, electrical problems or rattling caused by loose stems

Specifications

Sizes:
6.4 mm (1/4")
Materials:
Aluminium,
Steel Head
Style:
Protruding

Typical Placing Sequence

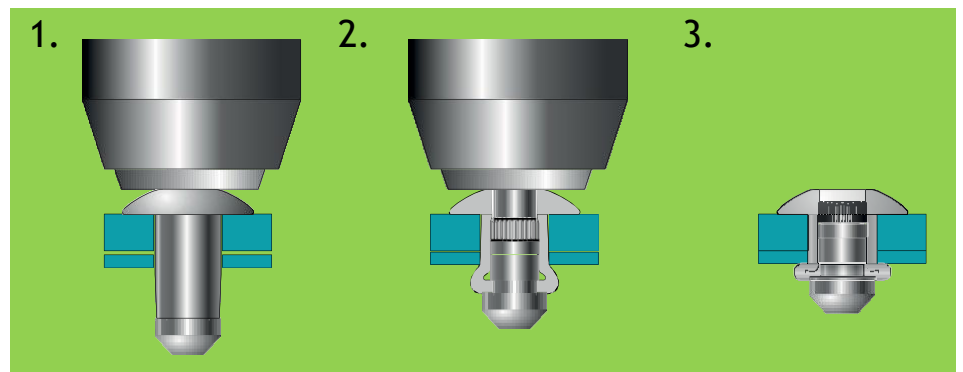

Assembly Applications for Hemlok Fasteners

- Automotive
- Warehouse racking
- Transport

