

Klamp-Tite[®] Fasteners

Aluminium alloy fasteners with a very large blind side bearing area against the rear sheet. Ideal for use in thin sheet or low strength materials.



Key Features and Benefits of Klamp-Tite Fasteners

- Split tail formation spreads the tail bearing load/ clamp load on the rear sheet
- Ideal for use in thin sheet materials offering high resistance to pull-out loads
- Multi-grip capability accommodates wide variations in material thickness
- Stem is mechanically locked into body providing very strong, vibration resistant joints
- Visible lock for quick and easy inspection
- Optional underhead washer provides a weather- proof seal

Specifications

Sizes:

4.8 mm and 6.4 mm
(3/16" and 1/4")

Material:

Aluminium

Head Style:

Protruding

Typical Placing Sequence

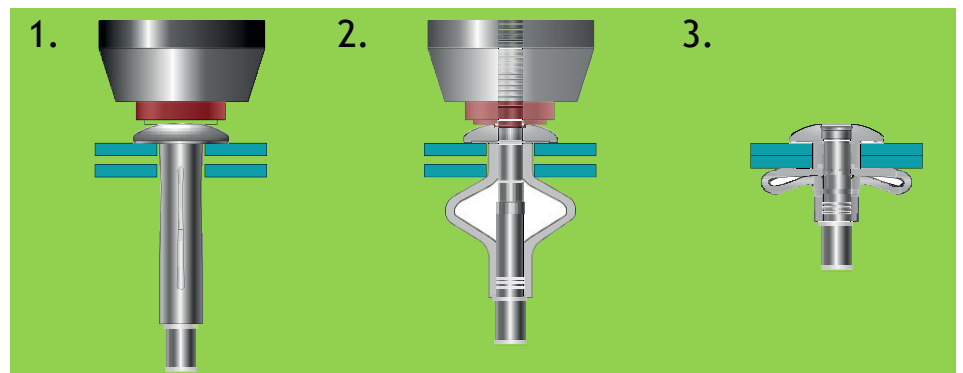

Assembly Applications for Klamp-Tite Fasteners

- Container
- Travel cases
- Cladding
- Commercial vehicles
- Plastic components

