

Monobolt[®] Fasteners

Multi-grip structural breakstem fasteners providing a fully sealed joint and visible lock.



Key Features and Benefits for Monobolt Fasteners

- Excellent hole fill via radially expanded body provides very strong, vibration resistant joints and compensates for irregular, oversized, slotted or misaligned holes
- Good sheet take-up performance for large gap closing capability
- Stem mechanically locked into body avoids damage, electrical problems or rattling caused by loose stems
- Multi-grip capability
- High shear and tensile strength
- Visible lock for quick and easy inspection

Specifications

Sizes:

4.8 mm, 6.4 mm and 10 mm
(3/16", 1/4" and 3/8")

Materials:

Aluminium, Steel,
Stainless Steel, A4

Stainless Steel Head

Styles:

Protruding, Countersunk

Typical Placing Sequence

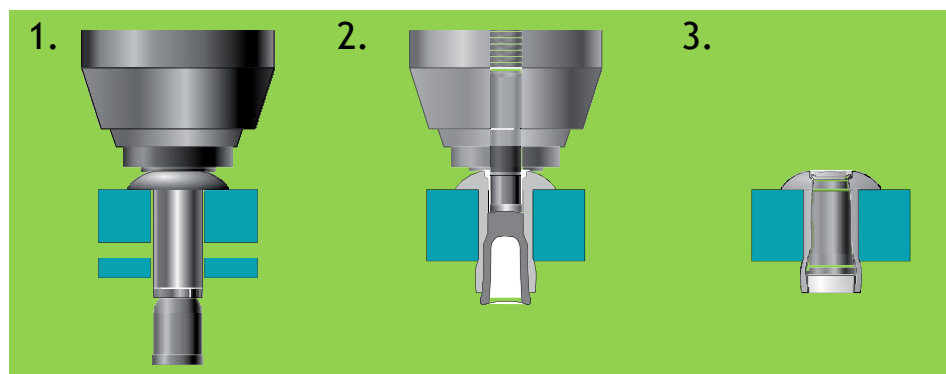

Assembly Applications for Monobolt Fasteners

- Truck and Trailer
- Cabinets and enclosures
- Rail
- Marine
- Farming and Agriculture

